

PART NAME

PLASTIBDX (STYLE C)

PART No.

PS-11276

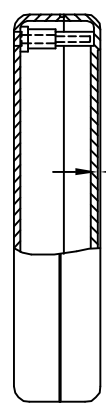
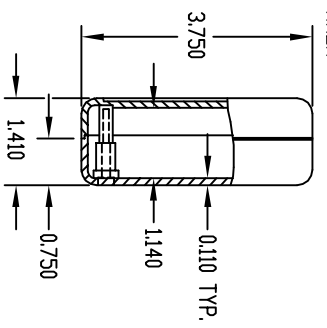
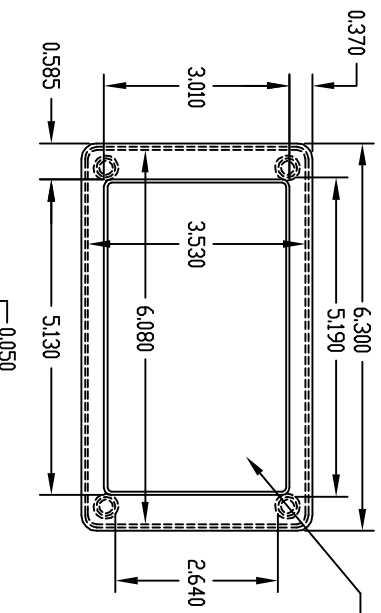

MATERIAL: HIGH-IMPACT POLYSTYRENE
 COLOR: PC BONE GRAY
 FINISH: TEXTURED BODY WITH SMOOTH TOP INSERT

FOUR (4) #4 x 0.625" LG. SCREWS SUPPLIED FOR ASSEMBLING TOP.

FOUR (4) NON-SKID FEET SUPPLIED.

USABLE BOARD AREA IS 3.500 x 6.060.

NOTE: ALL DIMENSIONS HAVE ±0.015 TOLERANCE UNLESS OTHERWISE SPECIFIED.

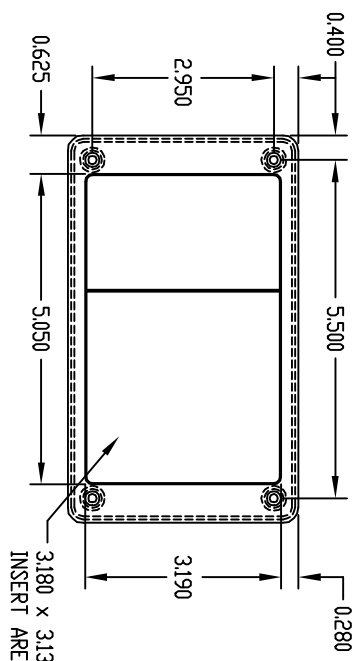

PART NAME

PLASTIBDX (STYLE D)

PART No.

PS-11279

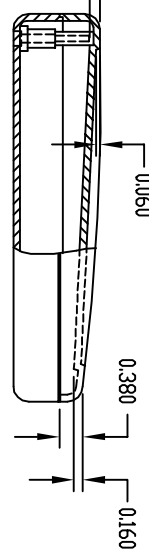
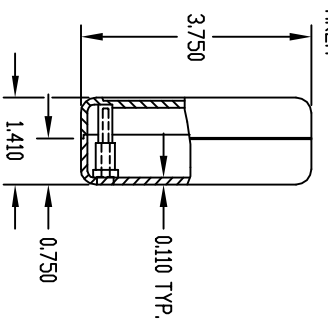
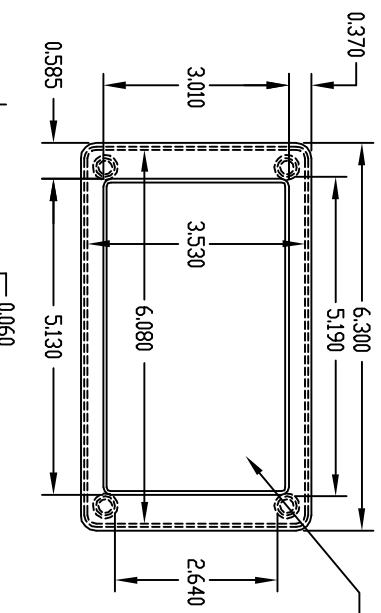

MATERIAL: HIGH-IMPACT POLYSTYRENE
 COLOR: PC BONE GRAY
 FINISH: TEXTURED BODY WITH SMOOTH TOP INSERT

FOUR (4) #4 x 0.625" LG. SCREWS SUPPLIED FOR ASSEMBLING TOP.

FOUR (4) NON-SKID FEET SUPPLIED.

USABLE BOARD AREA IS 3.500 x 6.060.

NOTE: ALL DIMENSIONS HAVE ±0.015 TOLERANCE UNLESS OTHERWISE SPECIFIED.

